

POWERFLEX®

PART NUMBER

PFR27- 611

DESCRIPTION

Rear Lower Arm Inner / Outer Bush Kit

INSTALLATION GUIDE

Contents (parts per pack):

- | | |
|-----------------------------|---|
| 2 x Polyurethane Bushes | 2 x Zinc-Plated Mild Steel Outer Shells |
| 4 x Stainless Steel Washers | 2 x Stainless Steel Sleeves |
| 1 x PTFE/Silicone Grease | |

Please read the complete fitting instructions and check package components before fitment. These fitting instructions are to be used as a guide and in conjunction with workshop manual.

It is recommended that:

- all work to be carried out by a licensed technician;
- all safety precautions adhered to;
- wheel alignment to be checked and adjusted as required after any suspension work.
- All fasteners must be tensioned to manufacturer's torque settings.

Fitting Instructions:

1. Remove the original bush from the arm, including any outer shell.
2. Clean any dirt or burrs from the bore in the arm, removing any sharp edges with a rounded file.
3. Press the plated-steel outer shell into the arm until flush with each side of the arm.
4. Apply some washing-up liquid to the bore of the shells, and press the polyurethane bush in until fully through the arm.

Tip: If you are having trouble pressing the bush in, try pressing the bush in at a slight angle so that one part of the lip is already in the bore of the shell, and when steady pressure is applied, the rest of the lip should follow.

5. Apply the supplied grease to the bore and the mounting faces of each bush.
6. Fit the stainless-steel sleeve into the bushes.
7. Apply grease to both faces of the bush, then place one washer on each face.
8. Tension all hardware to the manufacturer's recommended torque settings.

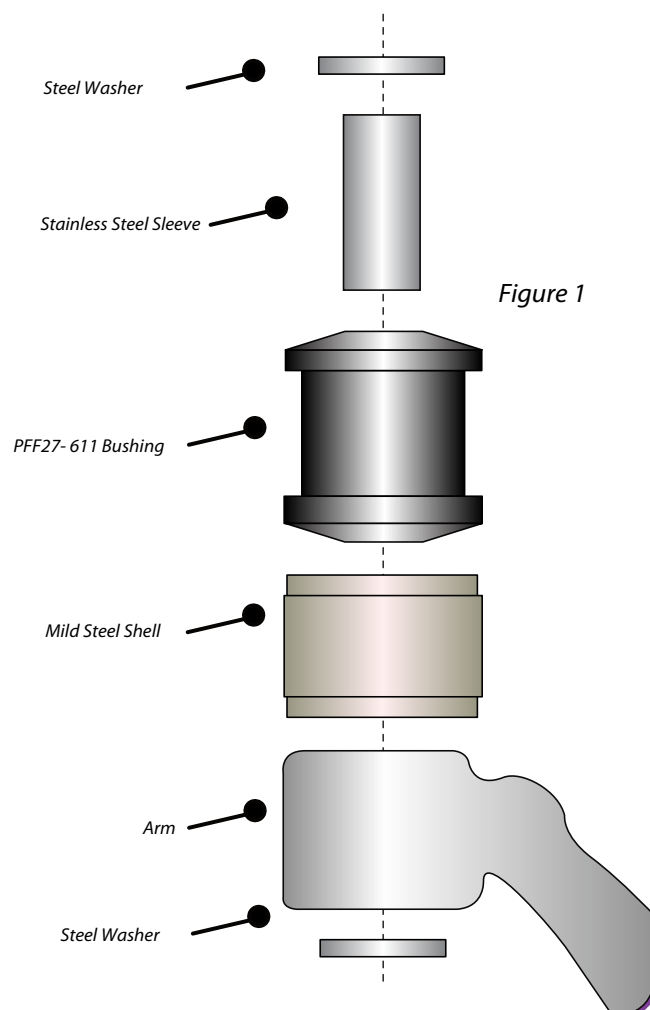

Figure 1